

2

1

B

B

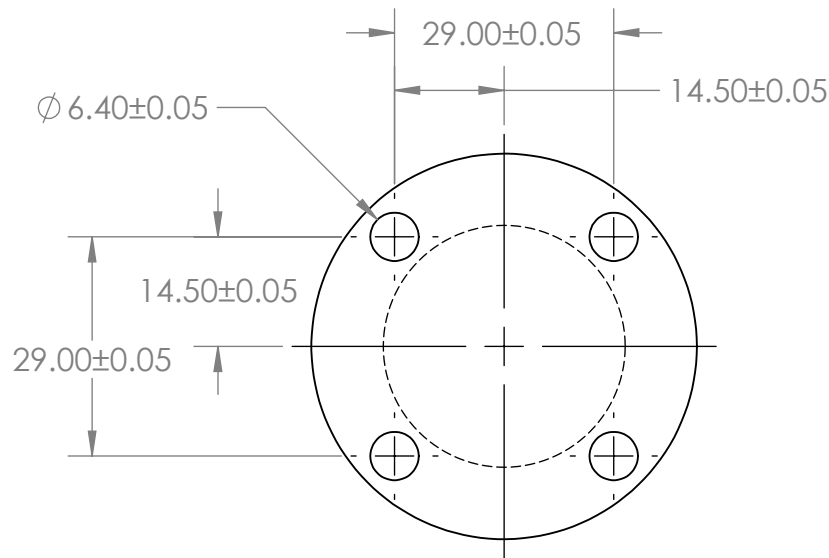
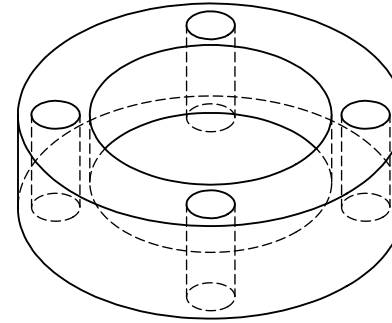
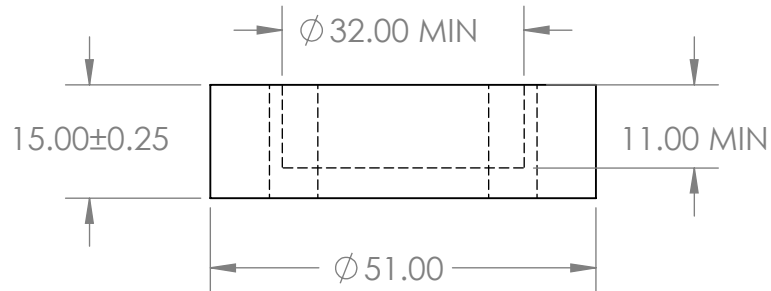

A

A

PROPRIETARY AND CONFIDENTIAL
 THE INFORMATION CONTAINED IN THIS DRAWING IS THE SOLE PROPERTY OF OPTC Devices (PDT Cal). ANY REPRODUCTION IN PART OR AS A WHOLE WITHOUT THE WRITTEN PERMISSION OF OPTC Devices (PDT Cal) IS PROHIBITED.

		UNLESS OTHERWISE SPECIFIED:		NAME	DATE	TITLE: Base for Final Prototype			
		DIMENSIONS ARE IN MM	DRAWN	Dinesh S	4/18/23			SIZE A DWG. NO. FP_Base_Schematic REV SCALE: 1:1 WEIGHT: SHEET 1 OF 1	
		TOLERANCES: FRACTIONAL \pm	CHECKED						
		ANGULAR: MACH \pm BEND \pm	ENG APPR.						
		TWO PLACE DECIMAL \pm	MFG APPR.						
		THREE PLACE DECIMAL \pm	Q.A.			COMMENTS: If spectralon does not fit smoothly into hole, more machining may be necessary Screw holes designed for M3			
		INTERPRET GEOMETRIC TOLERANCING PER:	NEXT ASSY USED ON APPLICATION DO NOT SCALE DRAWING						
		MATERIAL PEEK							
		FINISH							

2

1